

# ACES TRAINING SCHEDULE

---

# 2024 2025

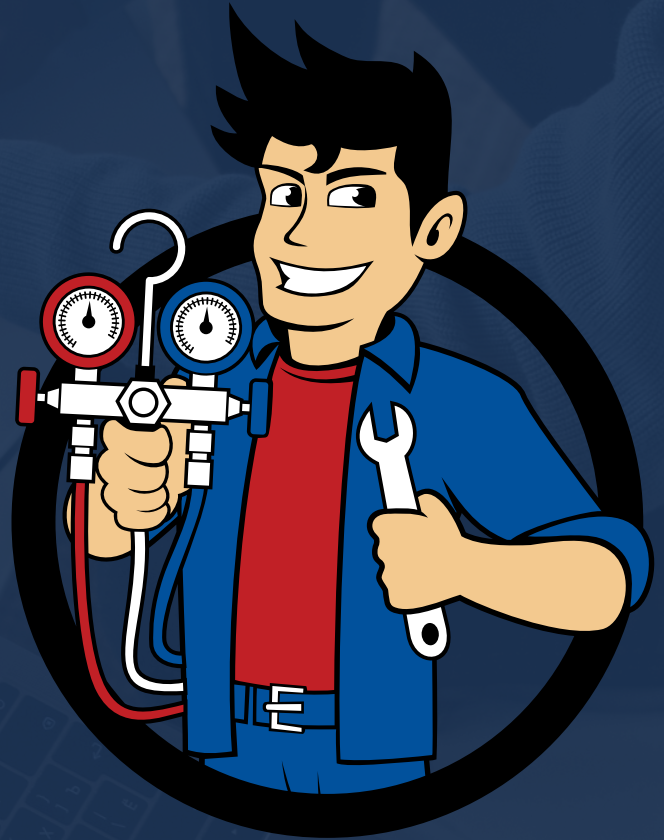

For over 40 years, ACES has been providing the highest quality training in the industry. Register today to get the knowledge and tools you need to compete in the ever-evolving HVAC landscape.

Use this QR Code, or go to <https://acessupply.com/training-sign-up> to register.



## Houston Training 2024-2024

Date	Class	Instructor	Location	Time	Price
10/1	Heating Diagnostics	Jimmy Davis	S. Loop	9 am 1	\$95
10/3	Commercial Installation and Startup	Jimmy Davis	S. Loop	9 am-1	\$95
10/8	Mistubishi Applications	Dwyer/Trumbly	S. Loop	8 am-3	No Charge
10/10	Zoning	Jimmy Davis	S. Loop	9 am-1	\$95
10/23	Welding AM	Jimmy Davis	S. Loop	9-10:30	No Charge
10/23	Welding PM	Jimmy Davis	S. Loop	1-2:30	No Charge
10/24	VS Certification	Jimmy Davis	S. Loop	9 am-1	\$95
10/29	Heating Diagnostics	Jimmy Davis	S. Loop	9 am -1	\$95
10/31	VS Advanced	Jimmy Davis	S. Loop	9 am-1	\$95
11/6	Business Training	Ron Collier	New Braunfels	9am - 4pm	\$350
11/12	Mitsubishi Application	Dwyer/Trumbly	S. Loop	8 am 3	No Charge
11/19	Mitsubishi Controls	Jimmy Davis	S. Loop	9 am-Noon	No Charge
11/20	VS Advanced	Jimmy Davis	S. Loop	9 am - 1	\$95
12/3	Mitsubishi Installation	Jimmy Davis	S. Loop	9 am -1	\$\$95-18 max
12/5	Commercial Installation and Startup	Jimmy Davis	S. Loop	9 am -1	\$95
1/9	Welding AM	Jimmy Davis	S. Loop	9-10:30	No Charge
1/9	Welding PM	Jimmy Davis	S. Loop	1-2:30	No Charge
1/14	Residential Installation and Startup	Jimmy Davis	S. Loop	9 am -1	\$95
1/16	Mitsubishi Controls	Jimmy Davis	S. Loop	9 am -Noon	No Charge

### Locations

S. Loop	ACES - South Loop 5801 S Loop East Houston, TX 77033
New Braunfels (Business Class)	Courtyard River Village 750 IH 35 North New Braunfels, TX 78130

Use this QR Code, or go to <https://acesupply.com/training-sign-up> to register.



**Maximum of 3 attendees per class per company.**

## Houston Training 2024-2024

Date	Class	Instructor	Location	Time	Price
2/11	Commercial Installation and Startup	Jimmy Davis	Houston South	9 am -1	\$95
2/25-26	Sales Training	Russ Horrock	S. Loop	9 am -4	\$600
3/18	Residential Installation and Startup	Jimmy Davis	S. Loop	9 am -1	\$95
3/20	Residential Installation and Startup	Jimmy Davis	S. Loop	9 am -1	\$95
3/25	Cooling Diagnostics	Jimmy Davis	S. Loop	9 am -1	\$95
3/26	Commercial Installation and Startup	Jimmy Davis	S. Loop	9 am -1	\$95
3/27	VS Advanced	Jimmy Davis	S. Loop	9 am -1	\$95
4/2	Cooling Diagnostics	Jimmy Davis	S. Loop	9 am -1	\$95
4/3	VS Certification	Jimmy Davis	S. Loop	9 am -1	\$95
4/8	VS Advanced	Jimmy Davis	S. Loop	9 am -1	\$95
4/9	Welding AM	Jimmy Davis	S. Loop	9-10:30	No Charge
4/9	Welding PM	Jimmy Davis	S. Loop	1-2:30	No Charge
4/10	Zoning	Jimmy Davis	S. Loop	9 am -1	\$95

**A2L/R454b information included in all AC training.**

### Locations

S. Loop	ACES - South Loop 5801 S Loop East Houston, TX 77033
New Braunfels (Business Class)	Courtyard River Village 750 IH 35 North New Braunfels, TX 78130

Use this QR Code, or go to <https://acessupply.com/training-sign-up> to register.



**Maximum of 3 attendees per class per company.**

## Southwest Division Training 2024-2024

Date	Class	Instructor	Location	Time	Price
9/12	Mitsubishi - Diamond System Builder	Mitsubishi Trainers	San Antonio	1 pm - 4 pm	No Charge
9/17	Mitsubishi - Diamond System Builder	Mitsubishi Trainers	Corpus Christi	9 am - 12 pm	No Charge
10/8	Variable Speed Certification	Eric Crader	New Braunfels	9 am - 2pm	\$95
10/10	Variable Speed Advanced	Eric Crader	New Braunfels	9 am - 2pm	\$95
10/30	Mitsubishi Applications	Mitsubishi Trainers	San Antonio	9 am - 4 pm	No Charge
11/5	Mitsubishi Applications	Mitsubishi Trainers	Round Rock	9 am - 4 pm	No Charge
11/6	Business Training	Ron Collier	New Braunfels	9am - 4pm	\$350
11/12	Mitsubishi Service/Installation	Eric Crader	New Braunfels	9 am - 2pm	\$95
11/13	Heating Diagnostics	Eric Crader	New Braunfels	9 am - 2pm	\$95
11/14	Mitsubishi Applications	Mitsubishi Trainers	Corpus Christi	9 am - 4 pm	No Charge
11/26	Symbio	Eric Crader	New Braunfels	9 am - 2pm	\$95
12/5	Variable Speed Certification	Eric Crader	Corpus Christi	9 am - 2pm	\$95
1/14	Variable Speed Certification	Eric Crader	New Braunfels	9 am - 2pm	\$95
1/21	Basic Principles of Air Conditioning	Eric Crader	New Braunfels	9 am - 2pm	\$95
1/23	Variable Speed Advanced	Eric Crader	New Braunfels	9 am - 2pm	\$95
2/4	Symbio	Eric Crader	New Braunfels	9 am - 2pm	\$95
2/6	Mitsubishi Service/Installation	Eric Crader	New Braunfels	9 am - 2pm	\$95
2/11	Basic Principles of Air Conditioning	Eric Crader	Corpus Christi	9 am - 2pm	\$95

Use this QR Code, or go to <https://acessupply.com/training-sign-up> to register.



AUS/Corpus Christi/SA - Sign up for Mitsubishi (except for 11/12 & 2/6) directly through the QR codes on their flyers in this book. They will not be available through the link above.

**Maximum of 3 attendees per class per company.**

## Southwest Division Training 2024-2024

Date	Class	Instructor	Location	Time	Price
2/25-26	Sales Training	Russ Horrock	Houston S. Loop	9 am -4	\$600
3/18	Cooling Diagnostics	Eric Crader	New Braunfels	9 am - 2pm	\$95
3/20	Zoning CLii & Link	Eric Crader	New Braunfels	9 am - 2pm	\$95
3/27	Symbio	Eric Crader	Corpus Christi	9 am - 2pm	\$95
4/3	Variable Speed Certification	Eric Crader	New Braunfels	9 am - 2pm	\$95
4/15	Variable Speed Advanced	Eric Crader	New Braunfels	9 am - 2pm	\$95

**A2L/R454b information included in all AC training.**

### Locations

New Braunfels	Courtyard River Village 750 IH 35 North New Braunfels, TX 78130
San Antonio	Embassy Suites Landmark 5615 Landmark Pkwy, San Antonio TX 78249
Round Rock	Embassy Suites by Hilton Round Rock 270 Bass Pro Dr, Round Rock, TX 78665
Corpus Christi	Marriott Residence Inn 309 S Shoreline Blvd. Corpus Christi 78401
S. Loop	ACES - South Loop 5801 S Loop East Houston, TX 77033

Use this QR Code, or go to <https://acessupply.com/training> -sign-up to register.



AUS/Corpus Christi/SA - Sign up for Mitsubishi (except for 11/12 & 2/6) directly through the QR codes on their flyers in this book. They will not be available through the link above.

**Maximum of 3 attendees per class per company.**



BUILT TO A HIGHER STANDARD  
*American Standard*<sup>®</sup>  
HEATING & AIR CONDITIONING

# WELDING CLASS

**Jimmy Davis - ACES Houston South Location**

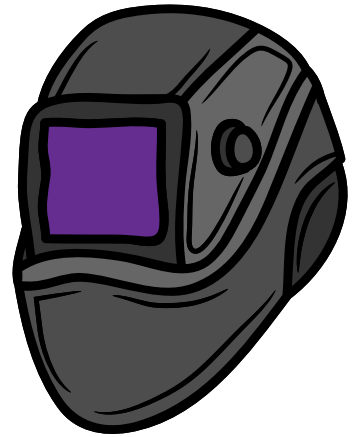
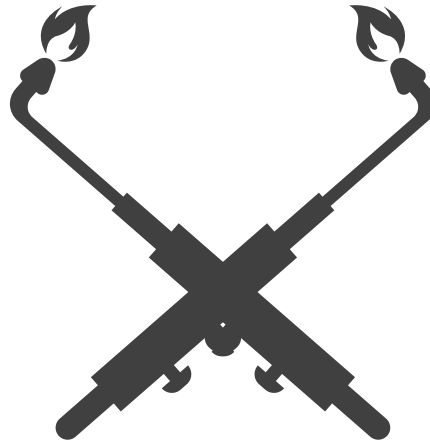
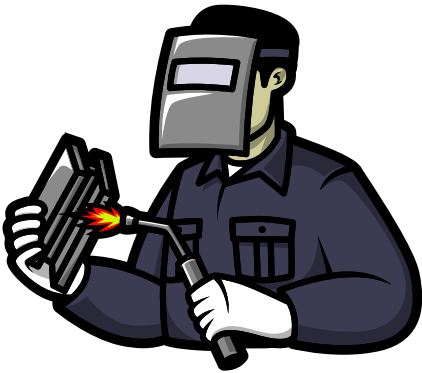

**Welding Techniques**

**Live Demos**

**Coil Repair**

**Aluminum Brazing**

**Copper Brazing**

**Torch Requirements**

**Solder Requirements**

**Houston South = 5801 South Loop East**



## Variable Speed - Certification

*(Zoning will be covered in separate class discussion)*



**Now Also Includes Link Communicating Systems**

- Before You Call
- Pipe Sizing
- Load Sizing
- Refrigerant System Charging
- Using Test Modes
- Sequence of Operation
- Low Voltage Wiring
- Compressor and Control Operation
- Compressor Updates

**Note: [asdealernet.com](http://asdealernet.com)  
username and password  
required.**





## Heating Diagnostics

Before You Call

### Gas Furnace Systems

- 80% Furnace Selection, Installation and Set Up
- \$95% Furnace Selection, Installation and Set Up
- High and Low Voltage Connection Diagrams
- o Twinning
- o 2 Step Cooling Wiring
- 7 Segment Display Menus
- Blower Settings for Correct Air Volumes/Airflow
- 9 Speed Constant Torque Motors
- LP Conversion
- Gas Inlet and Manifold Pressures

### Heat Pump Systems

- Thermostat Selection and Behavior
- Auxiliary and Emergency Heat
- Defrost Function
- Reversing Valve Function and Testing
- Electronic Expansion Valve Testing

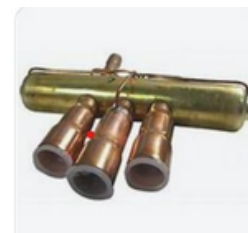
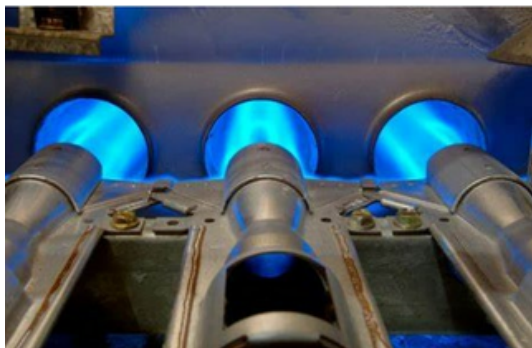





## Light Commercial Install & Startup

- Before You Call
- High and Low Voltage Connection Diagrams
- Living Without Service Valves - charging
- Pipe Sizing and Routing
- 3 Phase Indoor Motor Conversion 230 and 460v
- Residential AHU in Commercial Applications
- Indoor and Outdoor Accessories and Controls Blower Settings & VFD programming
  - Understanding RPM/CFM/Pully Charts
  - Blower Types and How to Adjust Each Type
- Leak Repair Copper and Alumin
- Condensate Management
- Options Modules
- Symbio Controls
- 24v Controls
- Wiring limitations
- Alert Codes
- Bluetooth Setup

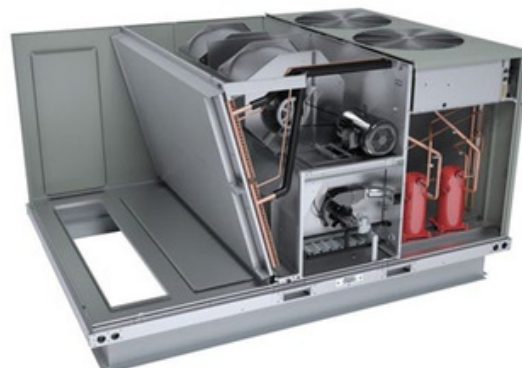
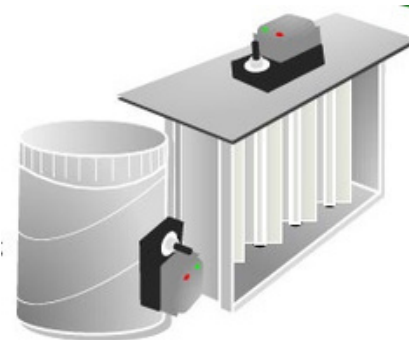



HEATING & AIR  
CONDITIONING

## Basic Principles Air Conditioning - Residential Installation & Startup

- Proper Installation & Clearances
- Static Pressure
- Airflow Setup
- Heat Kit Wiring
- TXC Placement
- Breaking Vacuum
- Identify causes from symptoms
- Copper Sizing
- Proper Charging
- Duct Placement on Plenum
- Soft Starts
- Leak Repair
- Brazing Best Practices
- Condensate Management

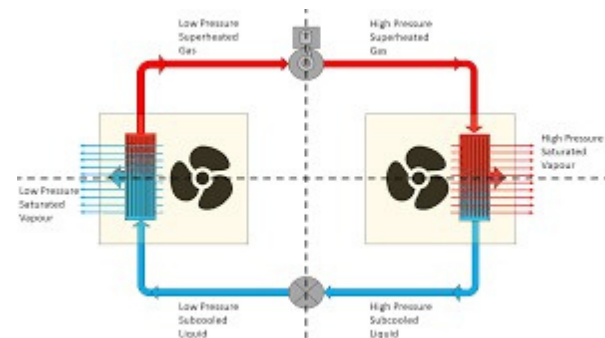
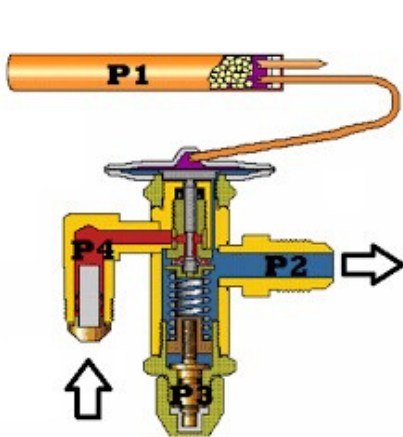



## Variable Speed – Advanced Diagnostics

*(Zoning will be covered in separate class discussion)*

### New Link System Controls and Operation

- Online Support and Diagnostic Materials
- Alert Code Diagnostics
- Interconnecting Wiring
- Thermostat Configuration
- Protections (Alerts) Descriptions and
- Correction Refrigerant Charging and Performance Curves
- Pipe Sizing and Routing
- Sweating Ducts and Humidity Management
- Software Updates
- Relay Panels
- VS Furnaces

**Note:**  
**asdealernet.com**  
**username and**  
**password**  
**required.**

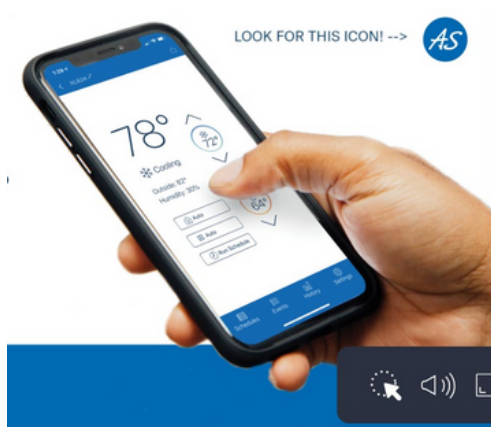

### S9V2 Wiring Diagram

S9V2 Wiring Diagram and Schematic

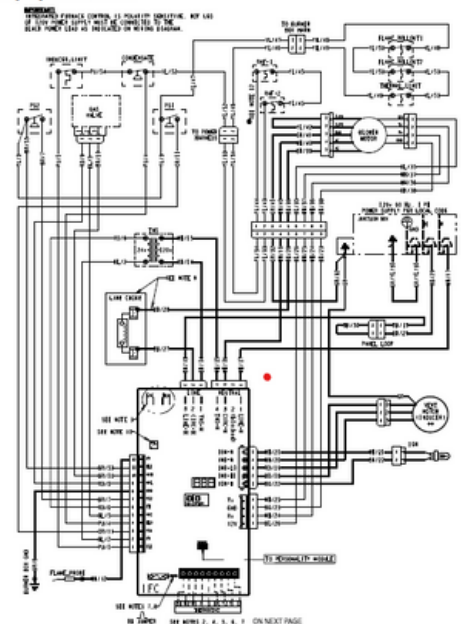



COLLIER  
CONSULTING  
GROUP



# PREPARING YOUR HVAC BUSINESS TO SCALE

ONE DAY OWNER'S WORKSHOP

Presented by Ron Collier, PhD

## Topics Covered

Scaling Verses Growth Sales,  
Marketing, Operations Systemization  
and Automation KPI's Operations  
and Financial Customer Acquisition  
Accountability Toward Goals Team  
Building Market Adaption Personnel  
Management Managing Risk Defining  
Roles Establishing Systems  
Utilization of Assets Communication  
Strategies Cost Controls Daily and  
Weekly Measurements

ACES A/C SUPPLY, INC.  
Courtyard by Marriott 750 IH35  
North New Braunfels, Tx.  
78130  
November 6, 2024 9:00am-  
4:00pm  
\$350 investment  
Use Cover link/QR Code to sign  
up.

There are over 30 million businesses in the United States and about 94% have revenues under \$1M. The other 6% have discovered growth, but the majority of those do not move past \$10M in sales. Growth can be easy, scaling is not. Growth can happen through revenue, market conditions, cost control, acquisitions and many other factors, but Scaling involves moving the entire company forward, not just a small portion. This HVAC workshop was designed for those companies who truly want to move their whole business up the ladder of success and not only grow but prosper in growth with double digit profitability. We will lay out a specific business plan with worksheets that will change the way you do business and change how as a leader you look at your company. Ron Collier, PhD has served the HVAC industry for over 30 years as a business management consultant. He has helped over 6000 contractors achieve financial success and has spoken often at national conferences including AHS, ACCA, PHCC, His latest book, *Profit is An Attitude*, reveals SMACNA, MCA, Comfortech, and Women in HVAC. successful strategies to make a profit in the HVAC industry.



## TECHNICIAN COMMUNICATION & SELLING SKILLS WORKSHOP

**February 25th - 26th, 2025**

**9:00 AM – 4:00 PM CT**

### **COURSE DESCRIPTION:**

The role of the technician is one of the most crucial roles in any home services business. They're not only the most common touchpoint with the customer, they're the one who actually enters the home – who must bring the proper customer experience in the front door. So how can you ensure that your team is walking in with a framework to seek perfection every single time?

In this in-person workshop you will learn what the perfect service call looks like. While that perfect experience is personal and will vary, most of the industry falls into two extremes: too opinionated, denying the customer information and options, or too sales-aggressive. There is a middle ground that has all the benefits and none of the downsides of those approaches. You will love what you do, but more importantly the way you did it, and every customer will feel they are valued and respected in their own home.

By focusing on the traits and behaviors of the best technicians and the art of effective communication, you can make your customers feel safe and confident in their decisions.

### **PLUS, YOU'LL LEARN:**

- The traits and behaviors of top-performing technicians
- The simplicity of effective communication
- How to make your customers feel safe regardless of their concerns
- How to deliver information with impact without applying pressure
- How to understand and know your customer so you can connect in a way they value
- How to stand out from your competition without slinging insults
- How to understand what “objections” really are and why they are so important
- And so much more!

### **LOCATION**

***ACES - South Loop***

5801 South Loop East, Houston, TX 77033

### **PRESENTER**



**RUSS HORROCKS**

**Vice President, Flow Odyssey**

Russ Horrocks emerged as one of the most successful Comfort Advisors in America in the mid-90's. Russ quickly took to sharing his unique knowledge of buyer psychology with sales forces across the country. He turned his profession into a passion, educating and coaching in-home sales and service advisors to understand the critical skills necessary to achieve results far exceeding personal mindset limitations and corporate expectations.



HEATING & AIR  
CONDITIONING

## Cooling Diagnostics

- Before You Call
- Pipe Size and Routing
- High and Low Voltage Connection Diagrams
- Blower Settings for Correct Air Volumes
- Refrigerant Charging
- Performance Curves (Charging)
- Brazing Best Practices
- Leak Repair Options
- Condensate Management
- Eliminating Sweating Ducts



Company Name _____	Technician name _____	Customer Name _____
Date _____	Indoor Unit Bulb _____	Outdoor Dry Bulb _____
Design outdoor pressure on charging chart _____	Outdoor Svc _____	Design discharge pressure based on charging chart _____
Outdoor Temp used to condense _____	Primary Voltage (kVahd) _____	Secondary (kVd) Voltage _____
Amps to outdoor motor _____	Compressor Amps _____	Compressor Run _____
Return temp at coil _____	Return temp at unit _____	Subcooling Target _____
Supply temp at coil _____	Supply temp at register _____	Subcooling Target _____
Number of green CFC bottles at air handler _____	Refrigerant Total Air Volume _____	
Leaking Air Temp _____	Line set length _____	Supply side with filter _____
Temp drop across filter and across return _____	Line Sizes _____	
Discharge Temp _____	Lift & S elbows _____	
Runback Press _____	Upward line temp _____	
Temperature across return from service valve _____	Liquid line temp _____	
Liquid Pressure _____	Superheat _____	
Vapor Pressure _____	Subcooling _____	
Cond Model # _____	Air Handler Model # _____	Coil Model # _____
Cond Serial # _____	Air Handler Serial # _____	Coil Serial # _____



# Zoning

## New Link Integrated System

- Added Features and Benefits
- New Controls and Other Components

## CLII and Eco-Jay

- High and Low Voltage Connection Diagrams
- Before You Call
- Benefits of Zoning
- Logic to Establish Separate Zones
- Evaluating and Resolving Temperature Variations between

## Zones

- Damper Types
- Zone Board Functions
- Other Zoning Controls and Accessories
- Supply and Return Grille Choices





## Mitsubishi Installation / Service

- Before You Call
- Installation Best Practices
- Wiring / Addressing
- System Charging
- Common Install Issues
- Functional Overview
- Troubleshooting





# Mitsubishi New Product Applications

IN-PERSON SEMINAR COURSE



Questions or Inquiries  
Contact

**Jimmy Davis**

[jimmyd@accessupply.com](mailto:jimmyd@accessupply.com)



Aces A/C Supply  
5801 S Loop East  
Houston, TX  
77033

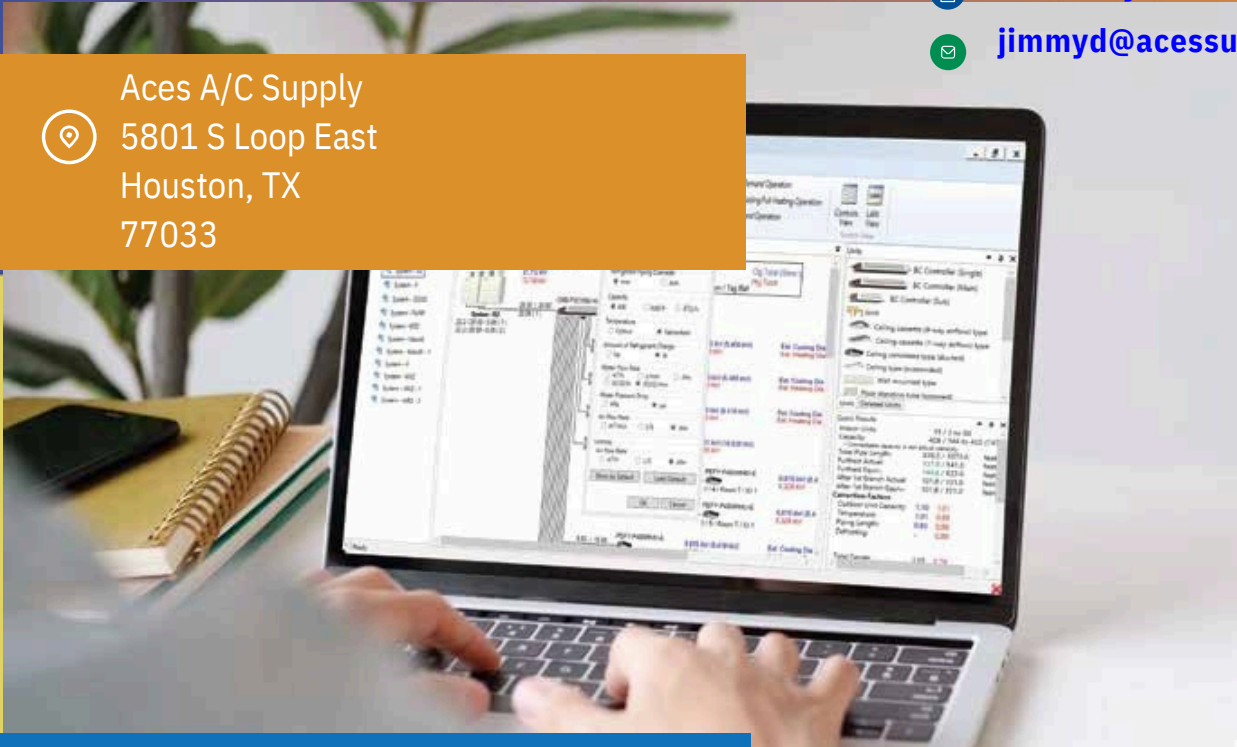

**October 8th**  
8AM - 4PM

## Subject Matter

The 1- day in person Applications Seminar course teaches the proper application and design of the new R454B Mitsubishi Inverter Heat Pump systems.

Participants will learn the new products available and best practices for applying these products in residential and light commercial spaces. The class culminates with the actual design examples using DSB software.

## Who should attend?

Owners  
Service Managers  
Sales Staff  
Install Managers  
Comfort Advisers

### Instructors:

James Dwyer  
Area Sales Manager South Houston  
David Trumbly

Area Sales Manager North Houston

LUNCH PROVIDED

FREE COURSE

# Mitsubishi New Product Applications

IN-PERSON SEMINAR COURSE



Questions or Inquiries  
Contact

**Jimmy Davis**

[jimmyd@acessupply.com](mailto:jimmyd@acessupply.com)



Aces A/C Supply  
5801 S Loop East  
Houston, TX  
77033

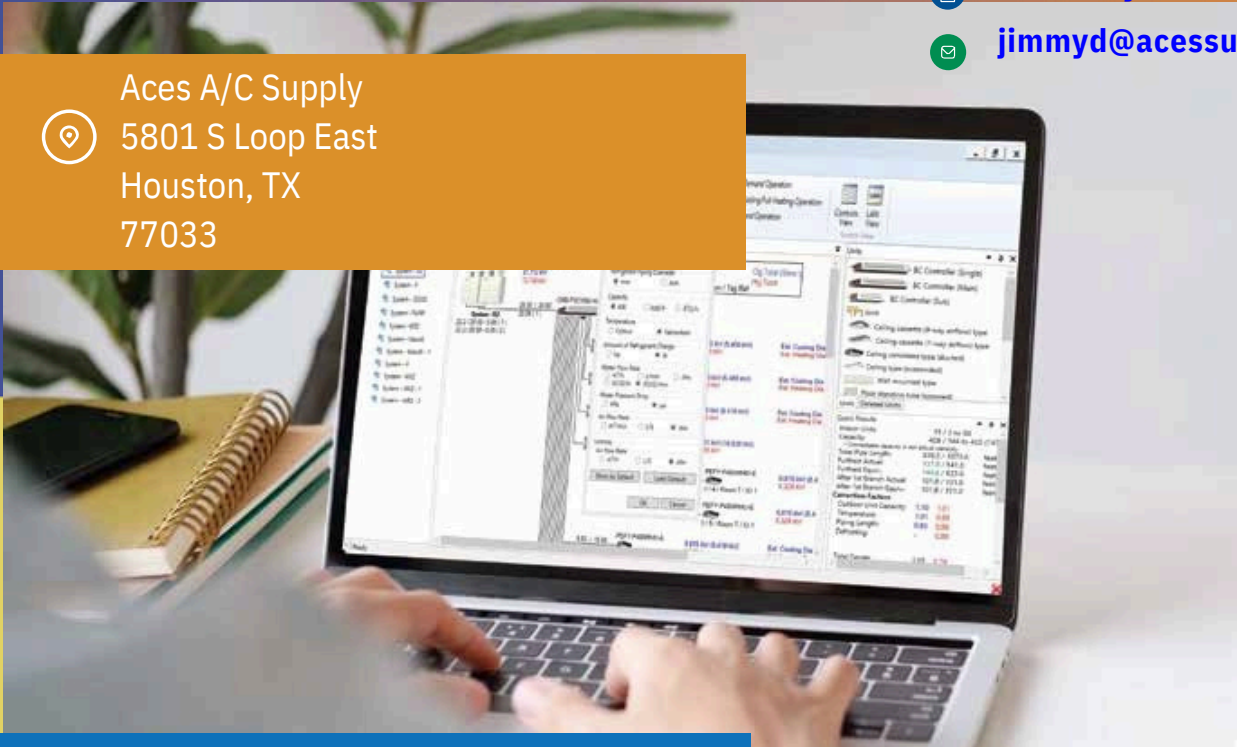

**November 12th**  
**8AM - 4PM**

## Subject Matter

The 1- day in person Applications Seminar course teaches the proper application and design of the new R454B Mitsubishi Inverter Heat Pump systems.

Participants will learn the new products available and best practices for applying these products in residential and light commercial spaces. The class culminates with the actual design examples using DSB software.

## Who should attend?

Owners  
Service Managers  
Sales Staff  
Install Managers  
Comfort Advisers

### Instructors:

James Dwyer  
Area Sales Manager South Houston  
David Trumbly

Area Sales Manager North Houston

LUNCH PROVIDED

FREE COURSE

**MITSUBISHI ELECTRIC**  
HEATING & AIR CONDITIONING

**ACES**



**FREE**

**SIGN UP TODAY**

# NV Series Controls

Residential and light commercial controls applications and operation

In person class  
Attendance limited  
Lunch provided

11/19	Mitsubishi Controls	Jimmy Davis	S. Loop	9 am-Noon	No Charge
1/16	Mitsubishi Controls	Jimmy Davis	S. Loop	9 am -Noon	No Charge



## Diamond System Builder Workshop

Learn how to design single zone & multi-zone VRF systems with no mistakes!

LIMITED SEATS AVAILABLE



September 17th



9am - 12pm



Embassy Suites Landmark

5615 Landmark Pkwy, San Antonio TX 78249

**How to Download DSB**



**Scan Me to RSVP**



**Only available on Microsoft Windows devices**  
*Please bring laptop with DSB software already installed*



## Diamond System Builder Workshop

Learn how to design single zone & multi-zone VRF systems with no mistakes!

LIMITED SEATS AVAILABLE



September 12th



1pm - 4pm



Embassy Suites

4337 S Padre Island Dr. Corpus Christi TX 78411

**How to Download DSB**



**Scan Me to RSVP**



**Only available on Microsoft Windows devices**  
*Please bring laptop with DSB software already installed*



**FREE**

# M&P Applications & Sales Workshop

**Click or SCAN to RSVP**  
2 GUESTS PER COMPANY



**Tuesday, November 5th**



**9am - 4pm (Lunch Provided)**



**Embassy Suites by Hilton Round Rock  
270 Bass Pro Dr, Round Rock, TX 78665**

**NEW**  
**A2L**  
**INFORMATION**

**Understand proper application**

**Develop in-home selling skills**

**Recognize Mitsubishi opportunities**

**Learn the tools that are available to you**

**How does Mitsubishi Electric fit into your business?**

**Learn the benefits of becoming a Diamond Contractor!**



**FREE**



**SCAN TO RSVP**  
LIMITED SEATING  
2 GUESTS PER COMPANY

# M&P Applications & Sales Workshop



**Wednesday October 30th**



**9am - 4pm**



**Embassy Suites Landmark  
5615 Landmark Pkwy, San Antonio TX 78249**

**NEW  
A2L  
INFORMATION**

**Understand proper application**

**Develop in-home selling skills**

**Recognize Mitsubishi opportunities**

**Learn the tools that are available to you**

**How does Mitsubishi Electric fit into your business?**

**Learn the benefits of becoming a Diamond Contractor!**



**FREE**



# M&P Applications & Sales Workshop

**SCAN TO RSVP**  
LIMITED SEATING  
2 GUESTS PER COMPANY



**Thursday November 14th**



**9am - 4pm**



**Marriott Residence Inn  
309 S Shoreline Blvd. Corpus Christi 78401**

**NEW  
A2L  
INFORMATION**

**Understand proper application**

**Develop in-home selling skills**

**Recognize Mitsubishi opportunities**

**Learn the tools that are available to you**

**How does Mitsubishi Electric fit into your business?**

**Learn the benefits of becoming a Diamond Contractor!**



# Notes

# Notes

# Notes

# ACES TRAINING SCHEDULE

---

2024

2025